

ENGLISH

Binatone Simply better

RECHARGEABLE FAN WITH LITHIUM-ION BATTERY



To get the best results from your Binatone product
please read these instructions carefully.

RCF-1865



Binatone has an incredible heritage.

Established – 1958 in London, UK.

We are an absolutely customer centric company!

With more than 60 years delivering quality products to our customers in more than 75 countries – our global footprint enables economies of scale.

This allows us to offer you some of the world's highest performance, quality & value products available in the market today.

Our commitment lies solely in delivering high quality, affordable products.

Our international team is constantly pursuing every effort to make products not just 'appliances' but 'lifestyle improvements'.

Check out all the latest Binatone products at:

www.binatonelifestyle.com



IMPORTANT SAFEGUARDS

When using electrical appliances – especially when children are present, basic safety precautions should always be followed to reduce the risk of fire, electric shock and/or injury to persons.

- ✓ READ ALL INSTRUCTIONS
- ✓ Make sure your power supply is consistent with the rated specification of the product before connecting.
- ✓ This appliance is not intended for use by persons (including children) with reduced physical, sensory or mental capabilities or lack of experience and knowledge – unless they are under supervision or instruction concerning use of the appliance by a person responsible for their safety. Children should be supervised to ensure that they do not play with the appliance.
- ✓ Do not operate any electrical appliance with a damaged cord or plug – or after the appliance malfunctions or has been dropped or damaged in any manner. Return the appliance to the nearest authorised service facility for examination, repair or adjustment.
- ✓ This product is intended for domestic indoor use only. Do not use outdoors or for commercial purposes.
- ✓ To protect against electric shock, do not place the product, cord or plug in water or other liquid.
- ✓ This product should not be used in the immediate vicinity of water, such as bathtub, washbowls, swimming pool etc. where the likelihood of immersion or splashing could occur.
- ✓ Unplug from the power outlet when not in use & before cleaning.
- ✓ Do not pull, twist or otherwise abuse the power cord.
- ✓ Use this appliance only for its intended use – as described in this manual.
- ✓ Do not insert fingers, pencil or other articles through the slots during operation.
- ✓ The use of accessory attachments not included, recommended or sold by Binatone is prohibited and may cause damage, fire, electric shock or injury.
- ✓ Do not operate the fan in the presence of explosive and/or flammable fumes.
- ✓ Do not place the fan or any parts near an open flame, cooking or other heating appliance.
- ✓ Do not operate if the fan housing is removed or damaged.
- ✓ Do not operate the fan without the protective front and rear grilles in position.
- ✓ Only use the AC/DC adaptor supplied with this product (marked for use with RCF-1865)
- ✓ To prolong the battery life – periodically plug in to AC power to recharge – for at least 8 hours, when the product has been stored for more than 3 months without use

SPECIFICATION

AC/DC adaptor Power:	AC 100-240V~ 50Hz 0.8A Max Model YR288A-01352500 (for use with RCF-1865)
Battery:	DC 11.1V 9000mAh Lithium-Ion type
Charging time:	Approx. 7-9 hours
DC Battery duration (fully charged):	
High speed fan:	Approx. 5-6 hours
Low Speed Fan:	Approx. 9-12 hours
Standby mode (LED):	Approx. 50 hours

KNOW YOUR APPLIANCE

CONTROL PANELS

Front Panel

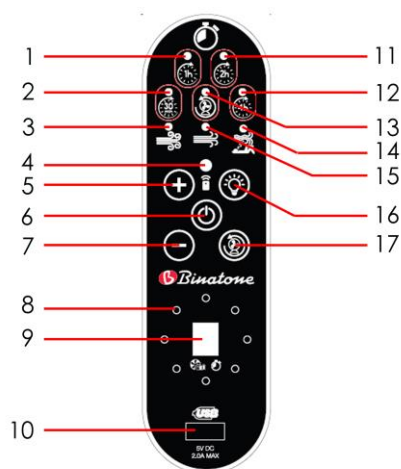

Remote Control

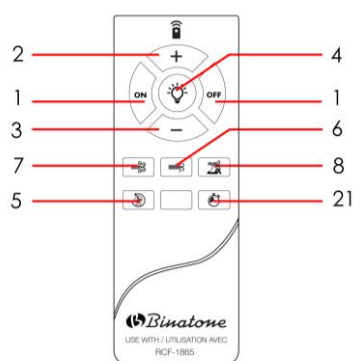

Rear Panel



- | | |
|----------------------------|--------------------------------|
| 1) Fan ON/OFF Button | 14) NATURE Mode LED |
| 2) Increase Button | 15) SLEEP Mode LED |
| 3) Decrease Button | 16) 30 min Timer LED |
| 4) LED ON/OFF Light Button | 17) 1 hr Timer LED |
| 5) Swing ON/OFF Button | 18) 2 hr Timer LED |
| 6) NORMAL Mode Button | 19) 4 hr Timer LED |
| 7) NATURE Mode Button | 20) Swing LED |
| 8) SLEEP Mode Button | 21) TIMER Button |
| 9) Remote Control Receiver | 22) AC/DC adaptor input (15V) |
| 10) LED Light | 23) Battery Door |
| 11) SPEED/TIMER Display | 24) Battery Door Screw |
| 12) USB Charge Socket | 25) AC/DC adaptor Charge Light |
| 13) NORMAL Mode LED | |

BEFORE FIRST USE

Carefully remove all packaging and assemble the product following the setup & operating instructions below.

SETUP INSTRUCTIONS

Battery Connection

For safety - this item is shipped with the battery disconnected - to connect it :

1. On the rear of the motor housing - remove the screw (24) at the top edge of the battery cover (23)
2. Remove the battery cover (24) by pulling the top edge outwards.
3. Remove the battery from the housing
4. Connect the battery to the socket inside the product – it will only fit one way.
5. Tuck the connected wires into the recess at the back of the battery compartment
6. Slide the battery into the compartment until it is fully seated.
7. Refit the battery cover (23)
8. Refit the securing screw (24)

Head Unit - Fan Blade & Protection Grille Assembly

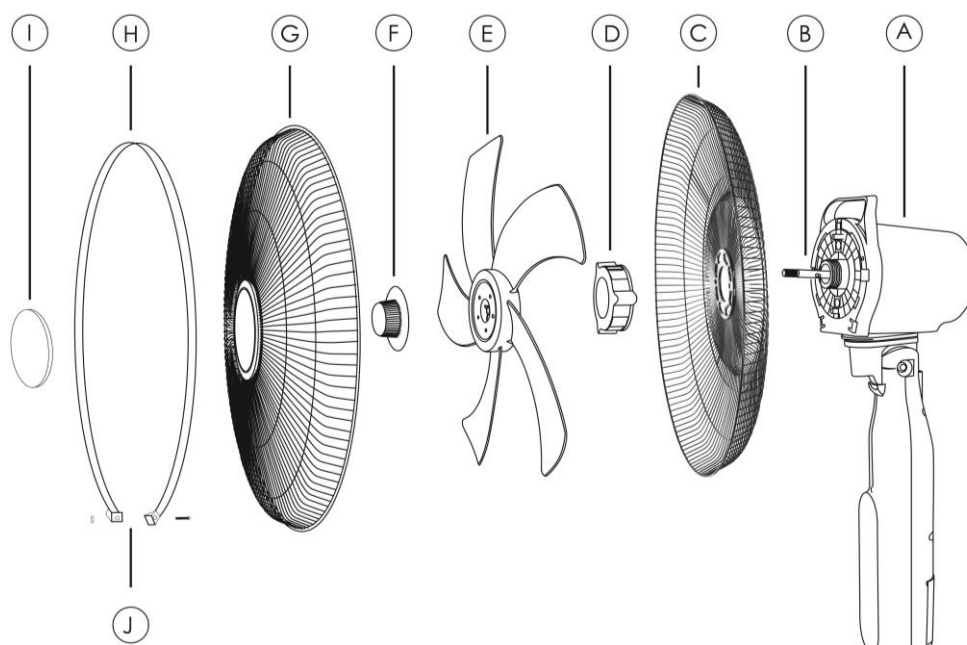

- | | | | | |
|------------------|----------------------------|----------------|----------------|--------------|
| A. Motor housing | B. Motor Shaft | C. Rear Grille | D. Plastic Nut | E. Fan Blade |
| F. Lock Nut | G. Front Grille & Diffuser | H. Trim Ring | I. Badge Cover | |

- Place the rear grille (C) on the motor housing (A)
- Secure it using the plastic nut (D) - turn clockwise to tighten by hand, do not over tighten
- Push the fan blade (E) onto the motor drive shaft (B) aligning it carefully
- Secure the fan blade (E) with the fan lock nut (F)
- Using the trim ring (H), assemble it together with the front grille (G) and rear grille (C). Tighten the lock screw on the trim ring (J)
- The Badge Cover (I) is secured to the front grille (H) by a bayonet fit. It can be opened by rotating counter-clockwise and closed by turning clockwise. The Badge Cover contains the 'Air Freshness' Module (see later section).

SETUP INSTRUCTIONS continued

Base Assembly - Telescopic Tube to Base

- Place the base (O) on the floor
- Insert the telescopic tube (M) into the recess on the top of base (O)
- Secure using washer (P) & screw (Q) provided
- Undo lock screw (N) & slide the upper telescopic tube (M) upwards.

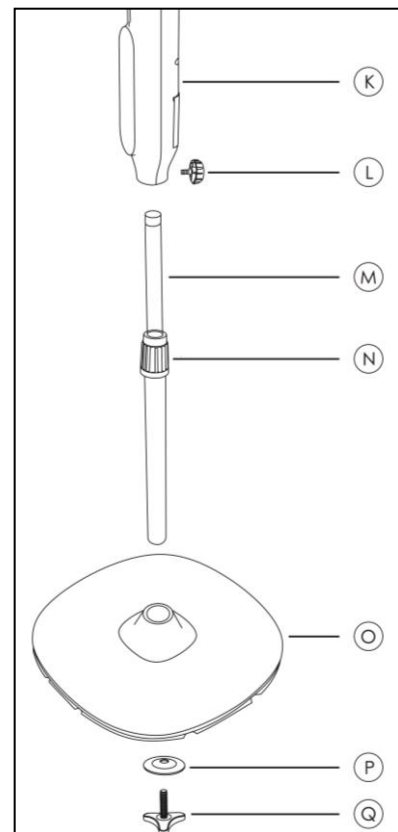

Head Unit to Base Assembly

- Undo the height adjustment knob (N) & pull the upper telescopic tube (M) upwards.
- Tighten the height adjustment nut (N).

Caution: The height adjustment knob (N) must be fully tightened before assembling the motor section to the pedestal stand assembly.

- Fit the head unit (K) to the base assembly and tighten the screw knob (L).

Caution: The screw knob (L) must be fully tightened before the fan is switched on.

OPERATING INSTRUCTIONS

1. AC/DC function

Connect the supplied AC/DC adaptor to a 230V~ outlet.

Connect the supplied AC/DC adaptor wire to the power input socket (22) on the rear panel of the stand fan.

All fan functions can be used, and the internal battery will be charged.

When AC power supply fails or is disconnected - the fan will automatically continue operation from the built-in battery.

2. Fan Operation



Press the on/off button (1) to switch on the fan.

Fan will commence operation on Speed 1 & NORMAL Mode LED (13) will illuminate.

Press the "+" button (2) to increase

Press the "-" button (3) to decrease

Press the on/off button (1) to switch off

Fan speed selected 1-9 will show on the Speed/Timer display (11).

OPERATING INSTRUCTIONS continued

3. MODE Function



The stand fan will start in NORMAL mode.

Press button (7) to select NATURE Mode

Press button (8) to select SLEEP Mode

Press button (6) to select NORMAL Mode

Note: The MODE selected will illuminate on LED's (13, 14, 15).

MODE	FUNCTION
 Normal	Conventional wind - at the set speed This can be used with all SPEED settings
 Nature	Creates an irregular & variable wind that is softer and more comfortable. This can be used with all SPEED settings
 Sleep	The fan speed will slowly decrease to aid sleep – as indicated below: 1) Speed 9 - fan operates for 0.5hr (30 minutes) then reduces to speed 5. After a further 0.5hr (30 minutes) it will reduce to speed 1 until the TIMER time is over or turned off. 2) Speed 5 – fan operates for 0.5hr (30 minutes) then reduces to speed 1 until the TIMER time is over or turned off. 3) Speed 1 - the fan operates until the TIMER time is over or turned off.

OPERATING INSTRUCTIONS continued

4. Timer Operation

Push the on/off button (1) to switch on & select the speed required

Press Timer button (21) on the remote control.

Press the "+" button (2) to increase (30 min steps)

Press the "-" button (3) to decrease (30 min steps)

Time selected 0.5 – 7.5 hours will show on the display LED's (16, 17, 18, 19).

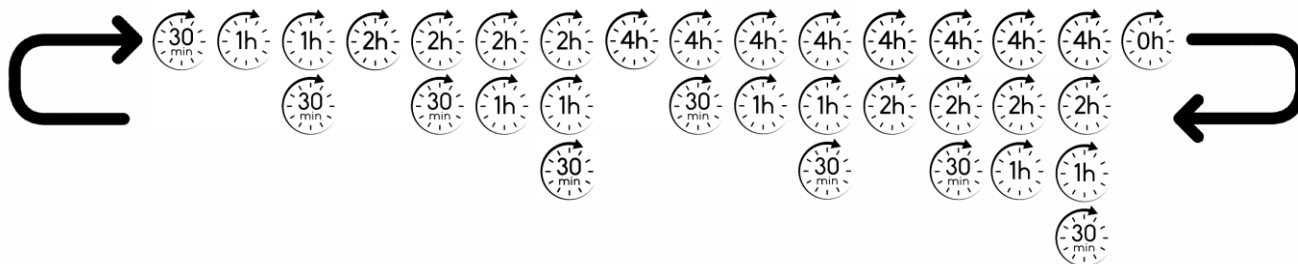

To cancel timer function, press Timer button (21)

5. Light function

The control panel has 8 bright LED lights built in - to operate :

Press LED light button (4) to turn ON

Press LED light button (4) to turn OFF

6. Swing

Fan head can be oscillated from left to right.

To start the oscillation – press the SWING button (5).

To stop the oscillation – press the SWING button (5).

7. Fan head tilt

The head tilt angle can be adjusted – carefully rotate the motor housing up or down - until the fan is angled as required - a series of clicks will be heard.

OPERATING INSTRUCTIONS continued

8. Battery charging

We recommend keeping the AC/DC adaptor connected when the fan is in regular use, to keep the battery fully charged.

You can run the fan without the AC/DC adaptor connected – however fan function will stop when the battery is empty.

To recharge the built-in battery, simply connect the AC/DC adaptor to the power input socket (22). The AC/DC adaptor has a Charge Light (25) on the back:

It will illuminate RED when charging

It will illuminate GREEN when the battery is charged

NOTE : When the fan will not be used for a while – we recommend ensuring the battery is fully charged, then disconnect the AC/CD adaptor and store carefully. The battery may need recharging every 3 or 4 months to keep it fully charged.

9. USB Charging Port

The USB charge port output is DC5.0V, 1A.

You can charge devices such as mobile phone, iPhone, iPad and many other USB charging electrical products: camera; power bank etc.

AIR FRESHNESS

The Air Freshness module can be used as an Air Freshener or as a Mosquito Repellent by soaking the provided sponge pads with appropriate liquids.



We recommend that the sponge pads are sprayed/soaked with appropriate liquid, depending on operation mode. The sponge pad should be thoroughly wet but not dripping wet before inserting to your fans Air Freshness module.



MOSQUITO
REPELLENT

Orange sponge pad

can be used exclusively for the soaking of mosquito repellent liquid(*)



AIR
FRESHENER

White sponge pad

can be used exclusively for the soaking of air freshener liquid.

To fit the sponge pad - firstly, locate and remove the Air Freshness module grille cap (18) on the front grille (17).

To unlock, rotate counter clockwise and remove the grille cap (18).

Fit the soaked sponge pad to the inside of the grille cap (18) - push it in carefully, the tabs will secure it in place.

Refit the grille cap/sponge pad assembly to the front grille (17) and rotate clockwise to lock in place. Operate the fan as usual, following the user guidelines.

Note: the soaked sponge pad will dry out as the liquid is dispersed - this is normal. We recommend checking and recharge the sponge pad every 3-4 hours.

(*) **CAUTION** : Select a safe mosquito repellent liquid for use with this product. Many insecticide type products are unsafe for humans and animals through inhalation or contact with skin & eyes.

Read the safety instructions of the repellent liquid carefully. If in doubt do not use it.



CARE AND CLEANING

This appliance requires little maintenance.

We recommend dust is cleaned from the fan blade and protective grilles every few months, to keep it operating optimally.

After use and before cleaning, ensure the fan is OFF and the blades have come to a complete stop.

Disassemble the front & rear grille & fan. Wipe parts with a damp cloth.

Do not use abrasive cleaners, harsh detergents, chemical cleaners or solvents as they may damage the surface finish of the plastic components.

Refit the parts following the assembly instructions

Wipe the outside of oscillating fan body with a damp cloth and dry with another cloth or paper towel.

BATTERY REPLACEMENT



The battery installed in this product can be replaced.

A replacement battery (part number 21700 9000mAh) may be obtained from your local Binatone Service Centre or directly through www.binatonelifestyle.com

- 1) Disconnect all power input to the fan
- 2) Remove the screw (24) securing the battery cover (23) on the rear of the main housing (K)
- 3) Remove the battery covered by pulling the top edge outwards
- 4) Carefully remove the battery & wiring – unclip the battery connector
- 5) Remove the old battery and recycle responsibly.
- 6) Fit the new battery
- 7) Reconnect the battery connector
- 8) Refit the battery cover (23)
- 9) Refit the securing screw (24)

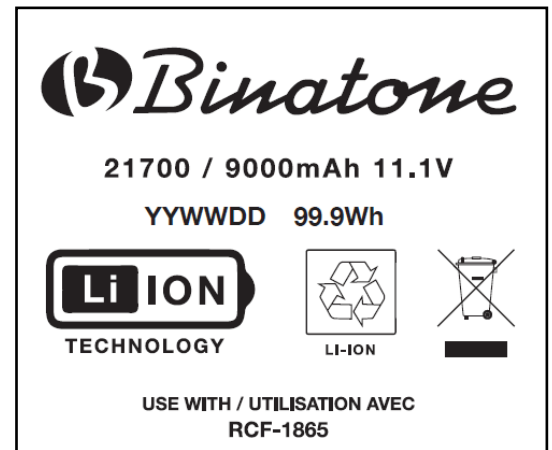

SERVICE & CUSTOMER CARE





There are no user serviceable parts inside this appliance.

If the power cord or plug are damaged it must, for safety reasons, be replaced by Binatone or an authorised Binatone repairer.

If you need help with:

- using your product
- servicing or repairs (in or out of guarantee)
- spare parts (fan blade, grille covers, locking nut)

Please contact Binatone Customer Service at:

	<p>www.binatonelifestyle.com/binatone/customer-service</p> <p>L</p>	
	<p>www.facebook.com/BinatoneAfrica</p> <p>or search @BinatoneAfrica in Facebook or Messenger to find this page easily.</p>	

Have your model number & batch code ready – it is located on the rating label on your product

WARRANTY



Save your proof of purchase sales receipt.

BINATONE warrants, subject to the conditions stated below, that from the date of purchase, this product will be free from mechanical defects for a period of two (2) years.

This is a domestic product – warranty does not cover products that have been used for commercial purposes.

BINATONE at its option, will repair or replace a product found to be defective during the warranty period. Should this product become defective by reason of improper workmanship or material defect during the specified warranty period, BINATONE will repair or replace the same effecting all necessary part replacements.

Transportation charges on parts, or products in whole, submitted for repair or replacement, under this warranty, must be borne by the purchaser.

CONDITIONS: This warranty is valid for the original retail purchaser from the date of initial retail purchase and is not transferable. Keep the original sales receipt. Proof of purchase is required to obtain warranty service or replacement. Dealers, service centres, or retail stores do not have the right to alter, modify or in any way, change the terms and conditions of this warranty.

Warranty registration is not necessary to obtain warranty on BINATONE products.

ABOUT YOUR PRODUCT WARRANTY: Most warranty repairs are handled routinely, but sometimes requests for warranty service may not be appropriate. For example, warranty service would NOT apply if the product damage occurred because of misuse, lack of routine maintenance, shipping, handling, warehousing or improper installation. Similarly, the warranty is void if the manufacturing date or the serial number on the product has been removed or the equipment has been altered or modified. During the warranty period, the authorized service dealer, at its option, will repair or replace any part that, upon examination, is found to be defective under normal use and service.

NORMAL WEAR & SERVICE/REPLACEABLE PARTS: This warranty does not cover normal wear of parts or damage resulting from any of the following: Negligent use or misuse of the product; Improper voltage or current; Use contrary to the operation instructions; Deviation from instructions regarding storage and transportation; Repair or alteration by anyone other than BINATONE or an authorized service centre; service parts replaced by user. Further, the warranty does not cover Acts of God, such as fire, flood, hurricanes, tornadoes etc.

Customers connecting BINATONE appliances directly to the mains power outlet or using a non-BINATONE stabilizer, risk voiding their BINATONE warranty. We recommend using quality BINATONE stabilizers for your protection – be wise, buy the best – always buy BINATONE

HOW TO OBTAIN WARRANTY SERVICE: Please contact BINATONE Customer Service (see Service & Customer Care section)



**Please consider recycling this
instruction manual responsibly**

Binatone Lifestyle Appliances

• LONDON • HONG KONG • DUBAI • LAGOS • ACCRA •